

PRODUCT OWNERSHIP GUIDE **STRENGTH**

PRODUCT OWNERSHIP GUIDE

Fitness equipment requires adjustments and maintenance that are part of owning or leasing equipment. These adjustments and maintenance are not part of your equipment warranty, nor are they defects in the equipment. The following will provide information on how to perform these adjustments and maintenance when needed.

Strength Equipment	3
Guide Rod Lubrication	4
Cable & Belt Tensioning	9
Rep Counter Battery Replacement	13
Securing Strength Equipment	14
Support Materials & Preventative Maintenance	16
Programs	18

STRENGTH EQUIPMENT

GUIDE ROD LUBRICATION

TOOLS NEEDED

- 6 mm Allen socket and ratcheting wrench
- 6 mm Allen T-handle wrench



Matrix equipment requires the following PTFE-based, non-aerosol lubricants:

- Super Lube with PTFE pump spray and grease (order [here](#))
- Tri-Flow with PTFE pump spray and grease (order [here](#))

Note: PTFE is Polytetrafluoroethylene (Teflon)

LUBRICATING EQUIPMENT

1. For **Ultra** use the 6 mm Allen socket to remove the top cover. Once the bolts are removed, take care when lifting the cover as there will be a rep counter wire that needs to be disconnected. If there is a monitor attached to the cover, the monitor wires must be disconnected.
For **Versa** use the 6 mm Allen socket, remove the top cover. Once the bolts are removed, take care when lifting the cover as there will be a rep counter wire that needs to be disconnected.
For **Aura** go to step 3.
2. Once the top cover is removed, remove the front weight stack shrouds.
3. With a clean rag, wipe the guide rods and the top of the weight stack so they are free from dirt and dust.
4. Spray a different rag with the required lubricant and wipe up and down the guide rod gently.
5. Holding the lubricant bottle 1"-2" from the top weight plate bushings, spray a small amount of lubricant between the bushing and the guide rod. Allow the lubricant to run down the guide rod inside the weight stack.
6. Do a few reps with light weight. Listen for noise and feel for friction. Repeat step 4 or 5 as necessary.
7. Wipe any overspray off the top weight plate.
8. Reinstall shrouds and top cover. Remember to plug in the necessary wires.

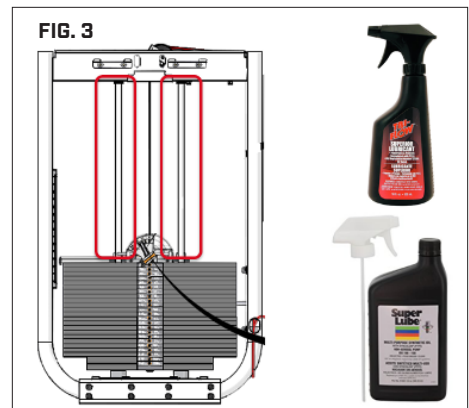
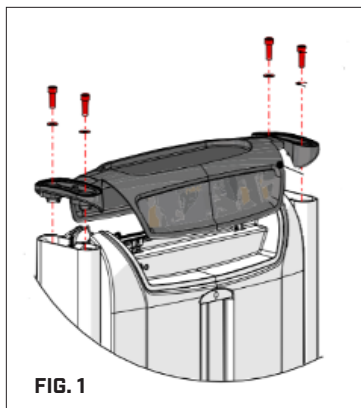

CABLE & BELT TENSIONING

Cables can stretch over their life and should be checked for proper tension and inspected for damage. Without proper tension, users will lose some range of motion and excess wear to the cables can occur.

Please refer to the Strength Cable & Belt Guide for tensioning procedures and how to identify damaged cables. See Support Materials section of this document for more information.

REP COUNTER BATTERY REPLACEMENT

TOOLS NEEDED

- 6 mm Allen socket and ratcheting wrench



Rep counters are powered by two AA batteries. When issues arise with rep counter windows not activating, replacing the batteries is all that may be needed.

STEPS

1. For **Ultra** remove the four bolts at the top of the weight stack. Slowly lift the top cover and unplug the wire. For **Versa** remove the two bolts securing the rep counter to the frame. Slowly move the rep counter away from the frame and unplug the wire.
2. Remove and replace the batteries.

Note: If one unit's batteries die, it is likely the rest are following shortly. Matrix recommends replacing the batteries on all units with rep counters at the same time.

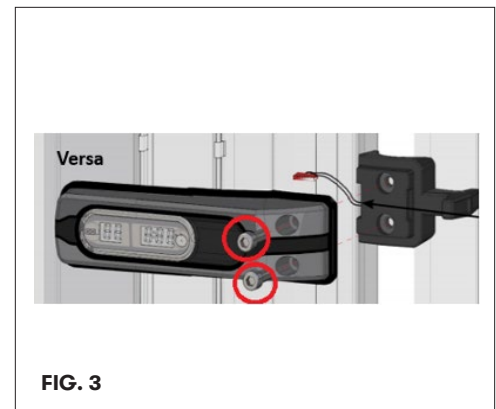
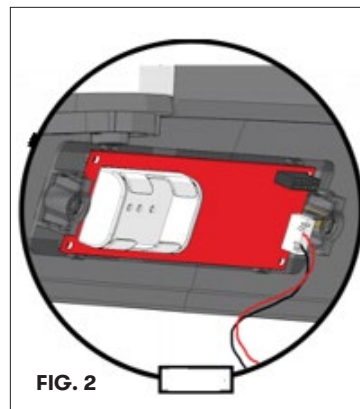
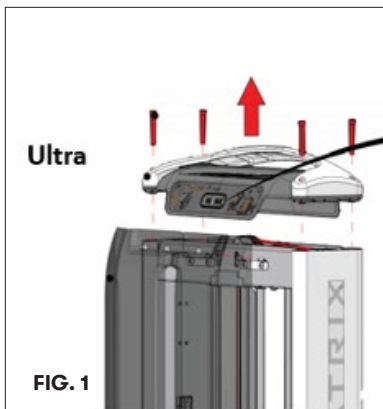

casall PRO

MATRIX EXCLUSIVE DISTRIBUTOR

STRENGTH:

BASIC CLEANING
AND MAINTENANCE
CHECKLISTT

The checklists below are maintenance recommendations beyond the daily cleaning of the equipment.

MATRIX SINGLE STATIONS: AURA, ULTRA, VERSA AND VERSA DUALS

Facility Staff Tasks	Jan	Feb	Mar	Apr	May	Jun	Jul	Aug	Sep	Oct	Nov	Dec
Wipe entire frame and pads with approved cleaner												
Clean and lubricate guide rods with approved lubricant												
Matrix-Certified Technician Tasks												
Visually inspect hardware for tightness												
Inspect belts/cables for damage												
Check belts/cables for proper tension												
Inspect pulleys for damage												
Perform a few reps with weight. Listen for noise, check smoothness												
Check rep counter/console for proper operation*												
Test push/pull pins for proper operation – ensure they are tightly secured to the frame then clean and grease												

QUARTERLY OR BI-ANNUALLY

Facility Staff Tasks	Q1	Q2	Q3	Q4
Wipe entire frame and pads with approved cleaner				
Clean and lubricate guide rods with approved lubricant				
Matrix-Certified Technician Tasks				
Visually inspect hardware for tightness				
Inspect belts/cables for damage				
Check belts/cables for proper tension				
Inspect pulleys for damage				
Perform a few reps with weight. Listen for noise, check smoothness				
Check rep counter/console for proper operation*				
Test push/pull pins for proper operation – ensure they are tightly secured to the frame then clean and grease				
Clean and grease all tie rod ends (see picture at right)				



*Ultra and Versa use 2-AA batteries.

The checklists below are maintenance recommendations beyond the daily cleaning of the equipment.

MATRIX MULTI-STATIONS

Facility Staff Tasks	Jan	Feb	Mar	Apr	May	Jun	Jul	Aug	Sep	Oct	Nov	Dec
Wipe entire frame and pads with approved cleaner												
Clean and lubricate guide rods with approved lubricant												
Matrix-Certified Technician Tasks												
Visually inspect hardware for tightness												
Inspect belts/cables for damage												
Check belts/cables for proper tension												
Inspect pulleys for damage												
Perform a few reps with weight. Listen for noise, check smoothness												
Test push/pull pins for proper operation – ensure they are tightly secured to the frame then clean and grease												

QUARTERLY OR BI-ANNUALLY

Facility Staff Tasks	Q1	Q2	Q3	Q4
Wipe entire frame and pads with approved cleaner				
Clean and lubricate guide rods with approved lubricant				
Matrix-Certified Technician Tasks				
Visually inspect hardware for tightness				
Inspect belts/cables for damage				
Check belts/cables for proper tension				
Inspect pulleys for damage				
Perform a few reps with weight. Listen for noise, check smoothness				
Clean and lubricate adjustable pulley chrome bars				
Test push/pull pins for proper operation – ensure they are tightly secured to the frame then clean and grease				

The checklists below are maintenance recommendations beyond the daily cleaning of the equipment.

MATRIX BENCHES

Facility Staff Tasks	Jan	Feb	Mar	Apr	May	Jun	Jul	Aug	Sep	Oct	Nov	Dec
Wipe entire frame and pads with approved cleaner												
Matrix-Certified Technician Tasks												
Visually inspect hardware for tightness												
Test push/pull pins for proper operation – ensure they are tightly secured to the frame then clean and grease												

QUARTERLY OR BI-ANNUALLY

Facility Staff Tasks	Q1	Q2	Q3	Q4
Wipe entire frame and pads with approved cleaner				
Matrix-Certified Technician Tasks				
Visually inspect hardware for tightness				
Clean and lubricate adjustable seat chrome bars				
Test push/pull pins for proper operation – ensure they are tightly secured to the frame then clean and grease				

MATRIX RACKS AND PLATFORMS

Facility Staff Tasks	Jan	Feb	Mar	Apr	May	Jun	Jul	Aug	Sep	Oct	Nov	Dec
Spot clean platform with approved cleaner												
Matrix-Certified Technician Tasks												
Visually inspect hardware for tightness												
Inspect all accessories for defect												

QUARTERLY OR BI-ANNUALLY

Facility Staff Tasks	Q1	Q2	Q3	Q4
Thoroughly clean platform with approved cleaner				
Matrix-Certified Technician Tasks				
Visually inspect hardware for tightness				
Visually inspect welds and accessories for defect				

GENERAL TORQUE SPECIFICATIONS

Below is a list of torque specs you should follow while checking tightness of your strength equipment. Note that we recommend applying red Vibra-Tite® Threadlocker to all frame bolts and axles.

Matrix part # ZMS4000792 or order here Vibra-Tite Threadlocker (Red)

KEY:

Axle Arm: 180 N-m / 133 ft. lb.

M10 Bolt & Nut: 77 N-m / 57 ft. lb.

M10 Bolt & Frame Rivnuts: 40 N-m / 30 ft. lb.

M8 Bolts: 25 N-m / 18 ft. lb.

M8 Plastic and M6 Bolts: 15 N-m / 11 ft. lb.

Pad Bolts: 10 N-m / 7 ft. lb.

A complete list of torque specs can be found in Online Remedy > Assembly Guide. You can also request them by contacting Customer Technical Support.

AURA: BELT TENSIONING PROCEDURE

- ▶ Loosen bolts on “fold over” clamp or “barrel” clamp
- ▶ Using your hand, pull out any slack of the belt and using a pliers on the cut end of the belt, pull to remove that slack
- ▶ Tighten bolts using the instructions below

Note: Three (3) squares of extra belt must show on the opposite side of the clamp when tightening bolts.

- ▶ For belting with the “fold over” clamp (Figure 1).
- ▶ Add Red Vibra-Tite® Threadlocker to the four bolts and tighten to 5 N-m using a torque wrench. The bolts should be tightened in a uniform pattern.

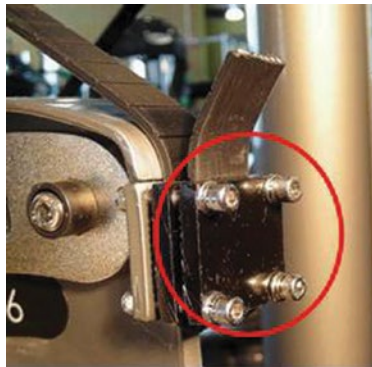

Figure 1

- ▶ For belting with the “barrel” clamp (Figure 2).
- ▶ Add Red Vibra-Tite® Threadlocker to the two bolts and tighten to 30 N-m using a torque wrench. The bolts should be tightened in a uniform pattern.

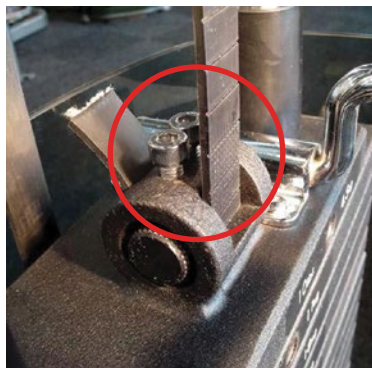

Figure 2

AURA: CABLE TENSIONING PROCEDURE

- ▶ Loosen the jam nut on the cable bolt above the weight stack
- ▶ Using your hand, pull any slack out of the cable and turn the cable bolt down removing the slack
- ▶ Once slack is removed, tighten the jam nut down using a wrench, finger tight is not good enough
- ▶ Insert weight stack pin into several different weight plates to ensure it goes in smoothly. If not, adjust cable tension back a bit until success



Note: On some machines, such as the cable Leg Press, there will be additional adjustment at the opposite side of the cable. Only adjust there if you run out of bolt threads above the weight stack.

ULTRA: CABLE TENSIONING PROCEDURE

- ▶ Loosen the jam nut and remove the weight stack pin
- ▶ Tighten cable bolt until head plate begins to move
- ▶ Tightening jam nut using a wrench
- ▶ Put as much weight on as possible, perform exercise to set cable
- ▶ Check cable tension with your finger pushing the cable from side to side
 - ▶ If the weight stack lifts (moves) when pushing the cable no more than 1 inch from the center, the cable is tensioned properly.
 - ▶ If the weight stack head plate does NOT move, repeat steps 1-4
- ▶ Check cable tension with your finger pushing the cable from side to side. If the weight stack head plate lifts (moves) when pushing the cable no more than 1 inch from the center, the cable is tensioned properly
- ▶ Check to make sure weight stack pin goes into every hole without hitting the bayonet

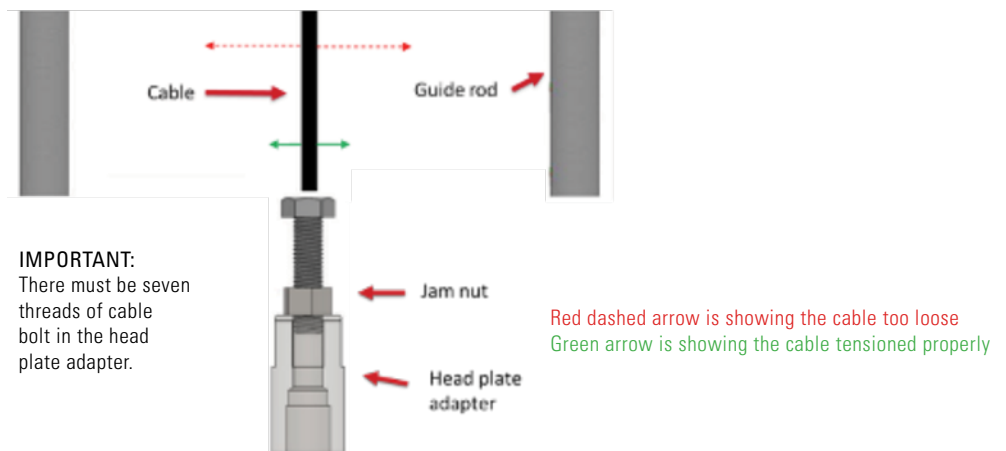

VERSA: CABLE TENSIONING PROCEDURE

- ▶ The cables on all Versa can be adjusted at the bottom portion of the weight stack.
- ▶ Loosen the two M10 bolts seen in the picture
- ▶ Use a 6mm hex wrench, turn the adjuster bolt up or down to tighten the cable
 - ▶ A properly tensioned cable will lift the head plate with 10–12 mm of deflection of the cable
- ▶ Torque the two M10 bolts to 77 N-m once the proper cable tension has been achieved

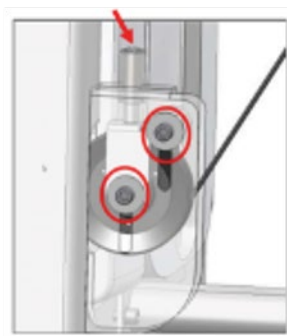

FUNCTIONAL TRAINERS AND MULTI-STATIONS – CABLE TENSIONING PROCEDURE

1. CHECKING FOR PROPER TENSION:

- ▶ Attach the bolt to the correct location (the weight stack or the carriage). Next, check the tension of the cable. Proper tension should leave 10mm of clearance between the stopper and carriage or pulleys, as shown in the tightest conditions. See diagrams below.

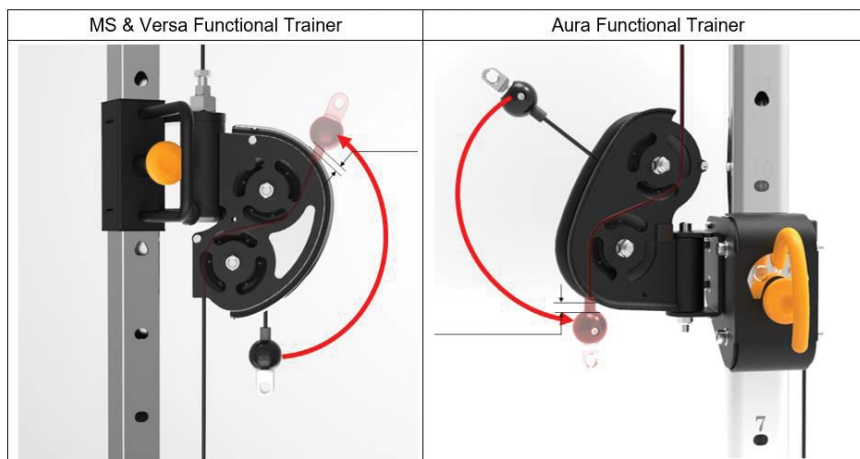

- ▶ If the stopper is too close to the carriage or pulley, use the adjustable wrench to loosen the bolt by a few threads. Important: A minimum number of threads must be engaged. Do NOT loosen any more threads if you can see 45mm of the bolt (measuring from the top). It is imperative that the jam nut on the bolt be tightened anytime an adjustment is made to secure the adjustment.



- ▶ Some units may have an adjustable pulley on top of the weight stack. If a unit has this and you can-not meet the 10mm clearance while keeping the minimum number of threads engaged, use a wrench and loosen the jam nut under the pulley housing. Turn the pulley housing down towards the weight stack until you have met the requirements. Use a wrench to tighten the jam nut.

FUNCTIONAL TRAINERS AND MULTI-STATIONS – CABLE TENSIONING PROCEDURE

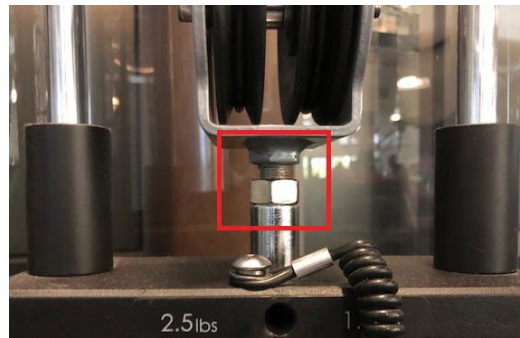

2. PRE-STRETCH OR “SET” THE CABLE

- ▶ Attached a short handle to the ball end of the cable then pin 50-70 lbs. on the weight stack.
- ▶ Do 5-10 reps at a rapid rate but do not allow the weight stack to crash down. You want to keep constant tension on the cable.
- ▶ Check the cable end measurement. Proper tension should leave 10mm of clearance between the stopper and carriage or pulleys as shown in Step 6.a. in the tightest conditions.
- ▶ Adjust cable as needed.

IDENTIFYING DAMAGED CABLES

FRACTURES

Casing can crack or fracture under strains during use. Any crack in the casing merits cable replacement even if no wire rope is exposed. Be especially observant for fractures near the components on the cable assembly - IE. Nylon Ball, Nico loop, Threaded Plug, etc.



TWISTING / BINDING

Inspect casing to ensure wire rope is not twisting within its casing. Any sign of the cable twisting should be replaced immediately.

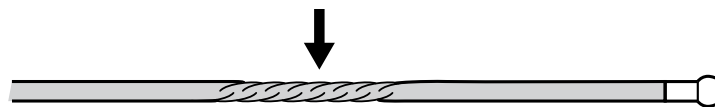

BULGING

Internal wire rope strands can break within and coil, causing a bulge to appear. Cables should retain the same diameter throughout.

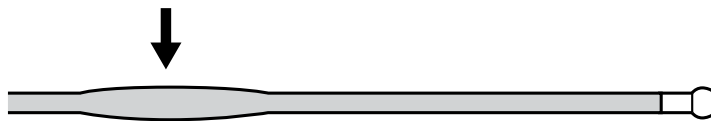

FRAYED / EXPOSED WIRE ROPE

Any exposed wire rope protruding through the casing or at either end.



FLATTENED

Section of cable is compressed and will not retain its shape (outside diameter).



IDENTIFYING DAMAGED CABLES

PERMANENTLY BENT

Cable has 'kink' and prohibits cable from laying straight. Wire rope may be unraveling beneath casing and is compromised warranting replacement.

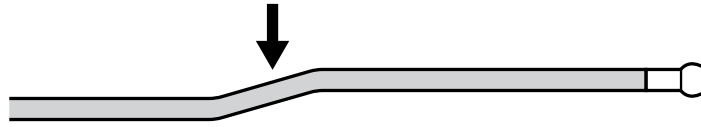

ENDS SEPARATING

Watch for component end of cable to pull away from cable assembly - look for exposed wire rope.

